

AQUANOVUS

INNOVATIVE AQUA ENGINEERING

As your trusted partner, we specialise in advanced technologies and product solutions designed to support and enhance water infrastructure worldwide.

www.aquanovus.net



AQUANOVUS ENGINEERING

THE FUTURE OF WATER

At Aquanovus, we specialise in the development of innovative water fittings that shape the future of modern infrastructure. We understand the critical need for solutions that minimise disruption while maximising efficiency. Our commitment to this principle is embodied in our flagship products, starting with the groundbreaking Novus Valve. This state-of-the-art under-pressure valve allows for installation without requiring a water shutoffs, a feature that significantly reduces service disruptions and saves invaluable time and resources for utility providers.

AQUANOVUS

Innovative Aqua Engineering



**Innovation
Technology**

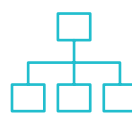

**In-House
Manufacturing
&
Development**



**Professional
quality control**



**Exclusive
Manufacturing
Partners**

Another key innovation is the Hydracut, an isolatable riser designed to simplify maintenance and repairs by allowing work to be performed on a specific section without affecting the main water supply. In addition to these industry-leading solutions, we also design and manufacture a comprehensive range of other essential fittings, including durable repair clamps built for long-term reliability.

What truly distinguishes Aqunovus is our integrated approach. Our team of in-house design engineers works in close partnership with our clients, transforming their concepts into tangible products. This collaborative process ensures that every solution is meticulously designed and precision-engineered to meet specific challenges. From the initial spark of an idea to the final product manufacturing, we pride ourselves on turning our customers' visions into reality. Our goal is to provide sustainable, efficient, and reliable solutions that ensure uninterrupted access to clean water for communities worldwide. This is our promise of innovation, quality, and partnership.

OUR CAPABILITIES



Your Partner in Custom Engineering and Manufacturing Excellence

At Aquanovus, we are more than a manufacturer; we are a dedicated partner in engineering innovation. With a team of highly specialised engineers and a commitment to end- to-end service, we take your vision and turn it into a certified, high- performance reality. We pride ourselves on having a team of engineers with extensive field experience, allowing them to anticipate challenges and devise solutions that are both elegant and robust. Our engineers are not just designers; they are problem solvers who collaborate with clients to push the boundaries of what' s possible, ensuring that every fitting we produce is not only functional but also optimised for durability, efficiency, and safety. This collaborative approach means we listen intently to your specifications, project goals, and operational environment, which allows us to create fittings that integrate seamlessly into your system.





OUR GLOBAL OUTREACH

Building on strong relationships with our international partners, Aquanovus supports a global network of companies.

We work in close partnership to **provide technical expertise, a reliable supply of innovative fittings, and dedicated local service** to each of our clients worldwide.

Scan to contact
EMEA SALES DIRECTOR



FOCUS ON INNOVATIVE AQUA TECHNOLOGY THROUGH CONTINUOUS R&D COMMITMENT

At Aquanovus, we are committed to pioneering innovative aqua technologies through continuous research and development. Our strong R&D team and robust manufacturing capabilities enable us to transform innovative fittings from concept to real-world application. We strive to be at the forefront of the aqua technology industry.

**Custom Tooling
Novusvalve Drill**

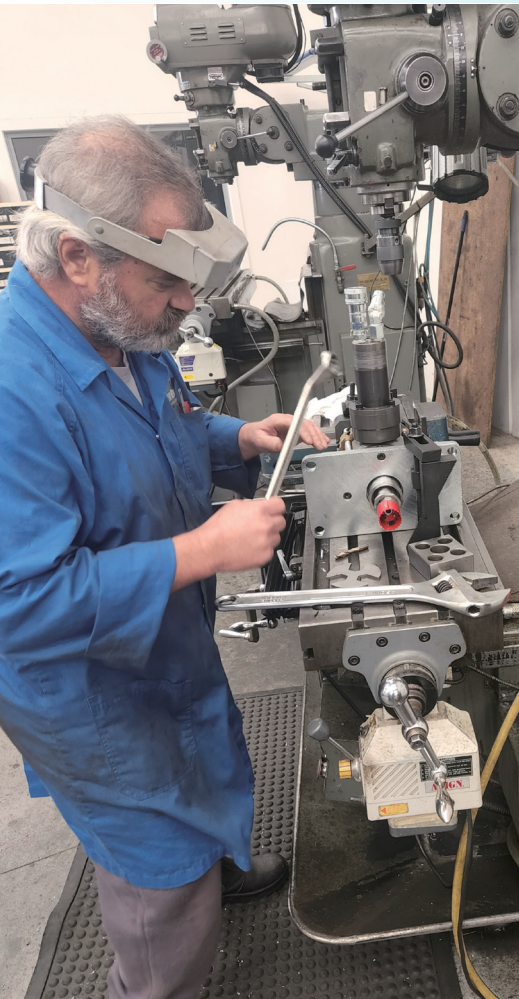

**Production Assembly
for our Clamps**

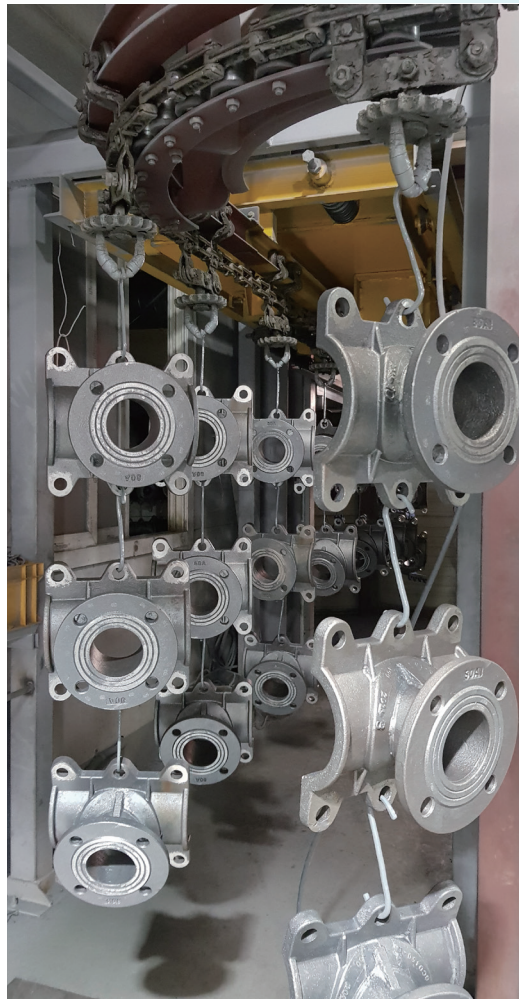

**Our New Product
Testing Facility**





Experience Driven Solutions

The Aquanovus team's strength comes from our developers' extensive field experience. This isn't just about technical skill; it's about a deep, practical background that provides them with an authentic, first-hand understanding of real-world challenges.

This hands-on perspective is what truly sets us apart, as it allows us to identify the nuances of complex problems from the ground up, not just in a theoretical context. As a result, we're uniquely positioned to design and develop innovative fittings that practical and effective solutions that stand up to the rigors of real-world applications.

NOVUS VALVE

A Pioneering Under pressure Inline Valve

The cutting- edge valve for under pressure pipe work

The Novus Valve is an innovative under-pressure valve that has been refined over many years, overcoming the limitations and challenges of original designs.

Engineered for rapid installation, it allows for seamless integration into a network without interrupting the water supply. This is made possible by our use of the End Mill (EM) drilling method, which significantly reduces the cutting area and eliminates the large, uneven surfaces often associated with conventional methods for installed pipelines.

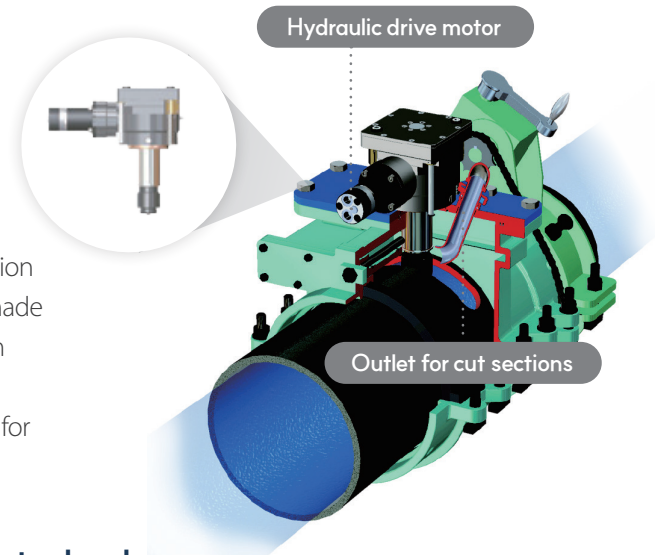

Our EM (End Mill) Under pressure drilling technology

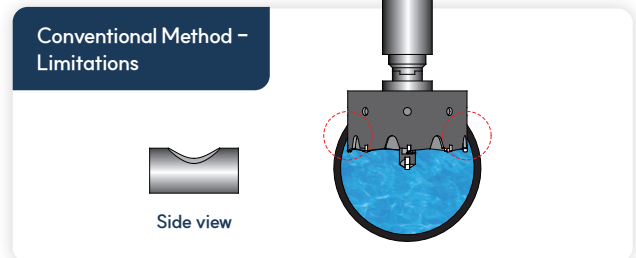
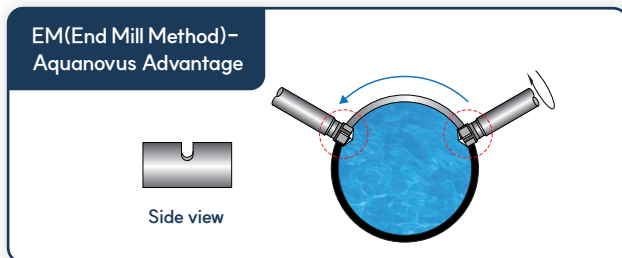

- ✓ High-torque, slow-speed milling protects infrastructure
- ✓ Uniform, safe finish with minimal cutting surface
- ✓ End mill does not protrude » consistent flow
- ✓ One-third the operating torque of older designs
- ✓ Minimal downward pressure » no strain on supply pipes
- ✓ Secure seal on ductile iron, PVC, PE, and more without rupture
- ✓ Customisable discs fit variable internal diameters

- ✗ Large surface area removed, weakening the pipe
- ✗ Uneven cut surfaces disrupt flow
- ✗ Cutting debris often enters the pipeline
- ✗ Detached coupons can fall into the main and obstruct flow
- ✗ Higher torque and pressure stress the pipe
- ✗ Shortens valve and pipe lifespan
- ✗ Limited adaptability to pipe variations

Installation procedure

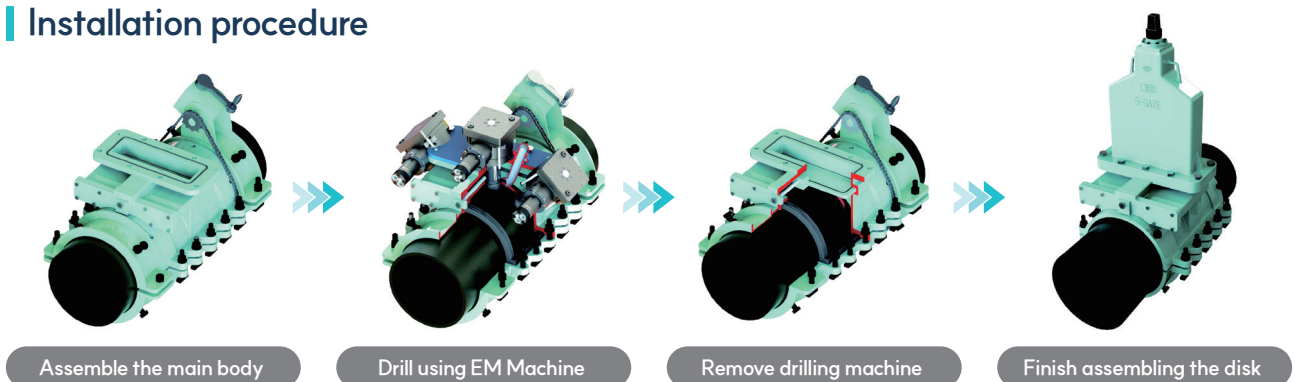

Assemble the main body

Drill using EM Machine

Remove drilling machine

Finish assembling the disk



WSAA



WRAS



NSF 61



EU - DWD



KWWA



AS/NZS4020

Key Technology 1

Low-torque operation

- The operating torque pressure has been reduced to one-third of the level compared to the previous model.
- The downward pressure exerted on the existing water supply pipes is minimised, avoiding strain on the pipe during shuts.
- Enhanced durability of components such as the operating unit and valve body has extended the valve's lifespan.
- Our valve disc is designed to provide a secure seal against pipes, including those made of PE or other impact-resistant materials, without any risk of bending, rupture, or breakage.



Key Technology 2

Our New Generation Disc

- Upon closure, the disc makes initial contact with two sides inside the pipe, then pushes aside any debris while achieving a tighter seal. Subsequently, the protrusion located in the center gradually steps down as it touches the bottom surface of the pipe. It allows greater adaption to all types of internal pipe condition.

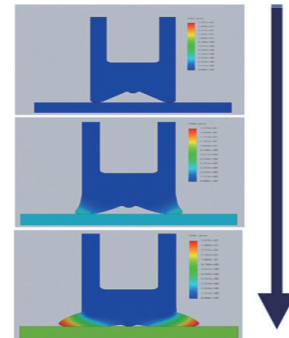
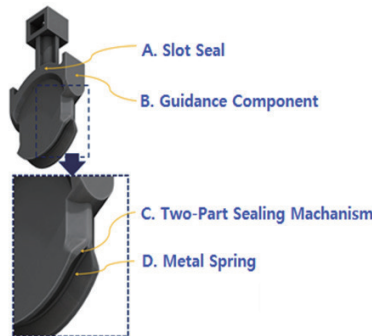

Key Technology 3

Capturing Various inner diameters of the pipe

- According to the statistics, PE pipes, PVC pipes, and others account for 40% of all water pipelines. Inner diameters of these vary depending on the type of pipe. For instance, in a 200mm pipe, there is a deviation ranging from -18mm to +12mm from the average inner diameter, underscoring the demand for tailor-made disks.
- Aquanovus has abilities to amend various sizes of the disc, therefore when specific sized discs are required, Aquanovus can manufacture the disc to suit.



Ductile Iron



Stainless



PVC



Steel

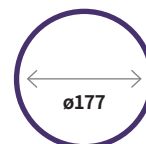

PE



Asbestos

OUR NOVUS VALVE INSTALLATION REQUIREMENT

Installation Specifications DN80 to DN350 Novus Valve - 2 Part Clamp System

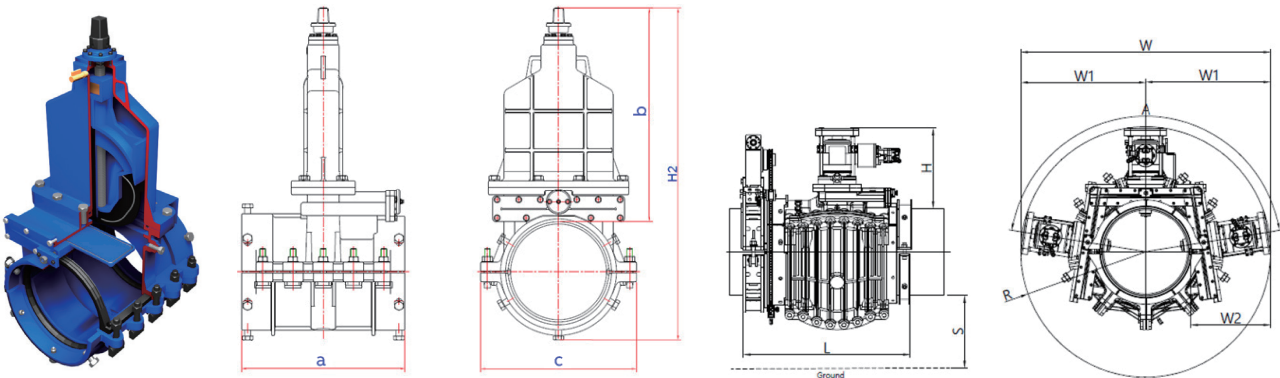

DN	Body			Number of Turns	Drilling Machine	Minimal excavation			
	a	b	c		H	W	W2	L	S
80	398	352	233	7	300	760	330	700	200
100	398	433	303	9		770	330	700	
150	448	498	331	13		840	330	750	
200	450	563	389	17		900	340	750	
250	520	638	444	21		970	355	820	
300	540	711	514	25	1,040	355	840		
350	650	833	598	29	330	1,080	355	950	

The product dimensions shown in the chart are for standard EU-sized ductile iron pipes. For specific product dimensions suitable on cast iron or asbestos pipes, including those used in the UK and Australia, please contact us directly. The sizes for these products may differ.



Installation Specifications DN400 - DN500 Novus Valve - 3 Part Clamp System

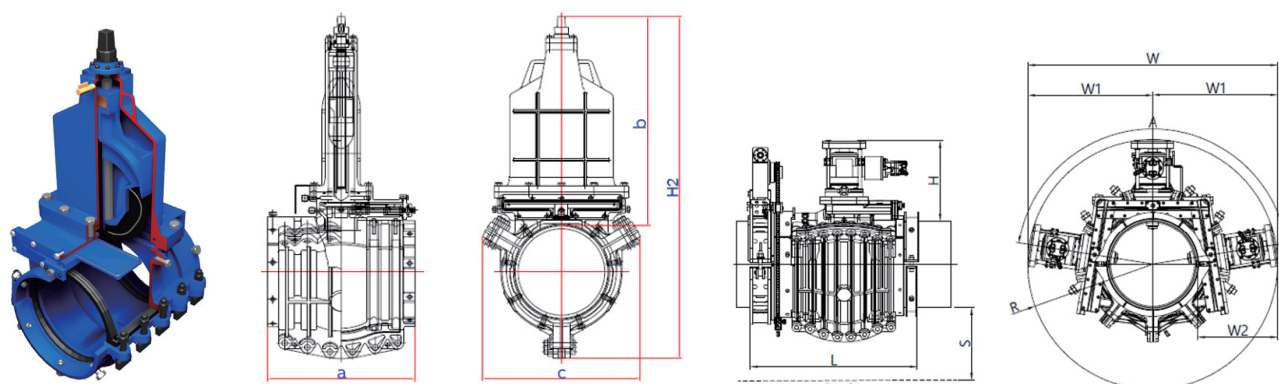

DN	Body			Number of Turns	Drilling Machine H	Minimal excavation			
	a	b	c			W	W2	L	S
400	680	970	727	33	600	1,600	575	980	300
450	770	1,080	814	37		1,700	575	1,070	
500	850	1,220	898	41		1,700	575	1,150	

The product dimensions shown in the chart are for standard EU-sized ductile iron pipes. For specific product dimensions suitable on cast iron or asbestos pipes, including those used in the UK and Australia, please contact us directly. The sizes for these products may differ.

Installation Specification for DN400 - DN600 GEN IV Novus Valve - 3 Part Clamp System with Compressed Bonnet

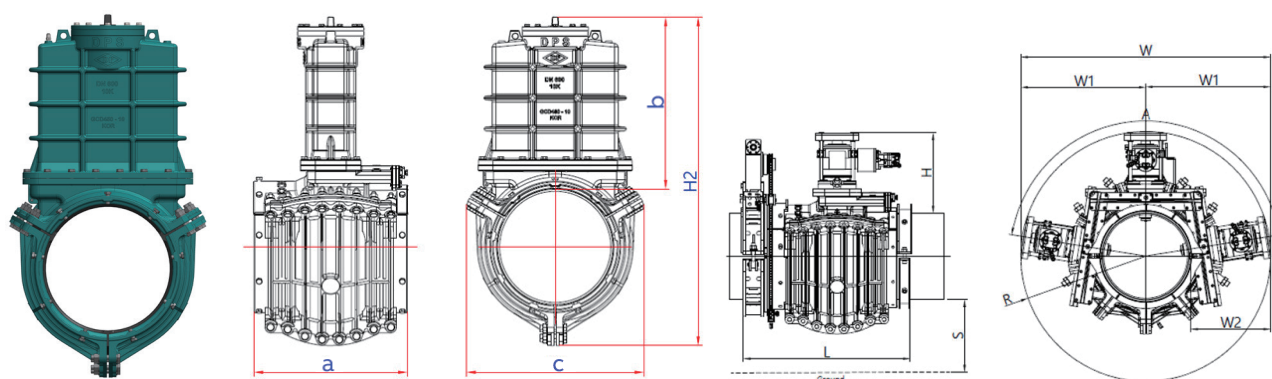

DN	Body			Number of Turns	Drilling Machine H	Minimal excavation			
	a	b	c			W	W2	L	S
400	680	746	727	33	600	1,580	800	980	300
450	770	811	814	37		1,630	850	1,070	
500	850	877	898	41		1,680	850	1,150	
600	850	948	978	49		1,800	850	1,180	

The product dimensions shown in the chart are for standard EU-sized ductile iron pipes. For specific product dimensions suitable on cast iron or asbestos pipes, including those used in the UK and Australia, please contact us directly. The sizes for these products may differ.

INTRODUCTION TO HYDRACUT – ISOLATABLE RISER

Product Specification

- Ductile iron body
- Primary Nominal Size - DN100
- Connection type - FLANGE / FLANGE
- Pressure rating - PN16
- Length: 180mm
- Stainless Steel with EPDM encapsulation

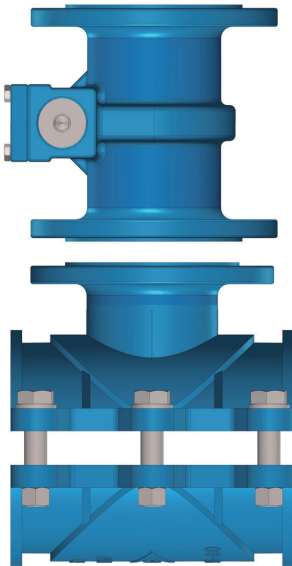
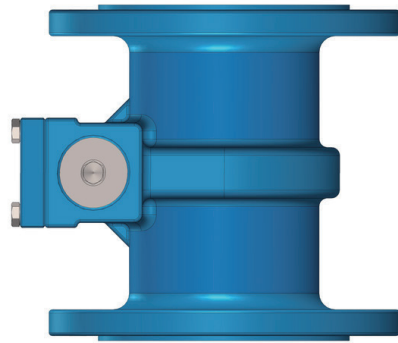

Benefits of the Hydracut

- When installed in a new pipeline, Hydracut allows temporary isolation of the riser component for hydrant replacement or temporary isolation.
- Hydracut can also be used in conjunction with a flanged offtake clamp to install hydrant into existing pipeline under pressure.



ROLL VALVE TECHNOLOGY

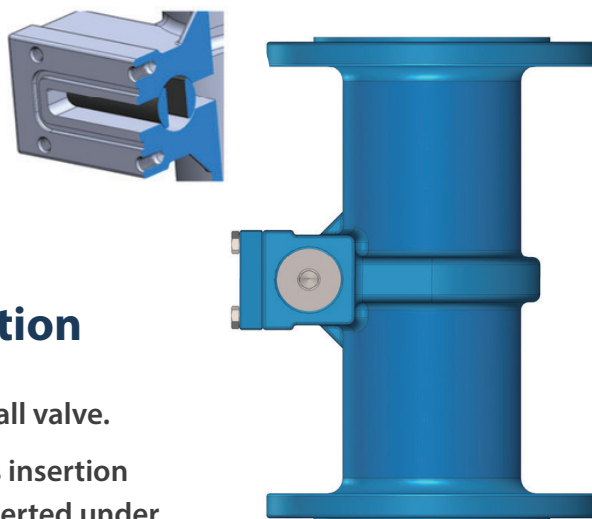

Hydracut roll valve function

- Operates on a principle similar to a ball valve.
- When roll valve is opened, this allows insertion of temporary isolation valve to be inserted under pressure providing isolation within the riser



DEAD PLATED

Side view of the Hydracut with the dead plate in place.

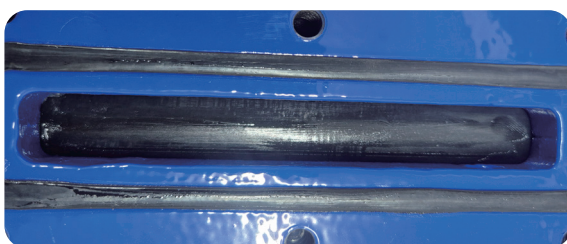

ROLL VALVE CLOSED

Side view of the Hydracut, showing the dead plate removed and the roll valve in the closed position.



ROLL VALVE OPENED

Side view of the Hydracut, with the dead plate removed and the roll valve in the open position

HYDRACUT ISOLATION PROCEDURE



Temporary Isolation Valve



DN100mm Hydracut

Isolation Process 1

Ensure Roll Valve key is accessible and clear of any obstruction for easy operation using appropriate allen key

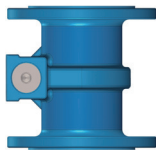

Isolation Process 2

Bolt on the temporary isolation slide valve to the side flange of the Hydracut

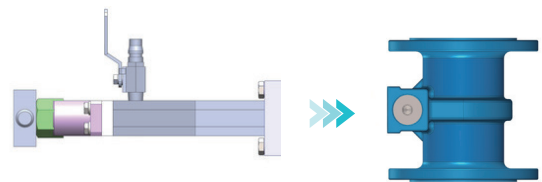

Isolation Process 3

Using an Allen key, turn the roll valve from the CLOSED to OPEN position.

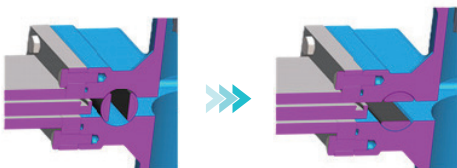

Isolation Process 4

Insert the temporary isolation slide valve fully. The riser is now isolated from main pressure.

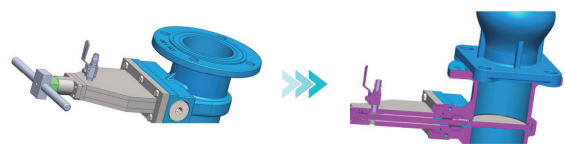

Isolation Process 5

Replace old hydrant with new spring hydrant or undertake maintenance. Isolation can be confirmed using the pressure release ball valve on temporary gate valve.

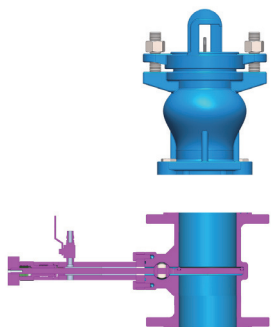

Isolation Process 6

To remove the temporary isolation valve from the riser, pull the temporary isolation valve outward.

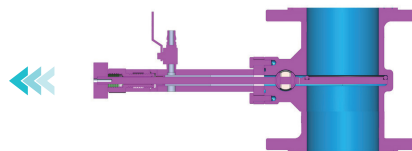

Isolation Process 7

Turn the roll valve from OPEN to CLOSED position. Confirm isolation using pressure release ball Valve on temporary isolation valve.

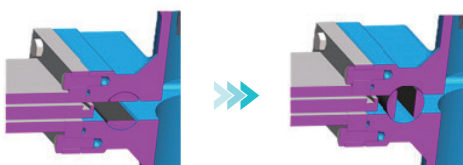

Isolation Process 8

Remove temporary isolation valve from the Hydracut riser, and bolt on blank flange

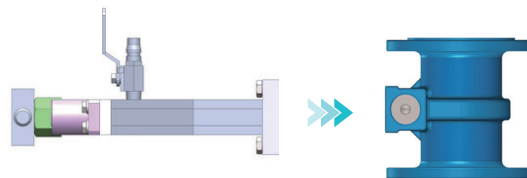

BENEFITS OF USING HYDRACUT



No Disruption to Our Service

Our innovative method allows hydrant replacement without interrupting water supply. A temporary isolation valve is easily inserted, eliminating the need to shut off the main. Therefore, critical customers are unaffected as the water network remains live during maintenance.



Minimised Night Work

By avoiding water outages, maintenance can be conveniently scheduled during day light hours, minimising disruption and improving worker safety. Critical customers remain unaffected as the water network stays live.



Flexibility to the Construction program

Hydrant replacements, can be performed efficiently without delays associated with traditional methods.



Less Water wastage

Our approach eliminates the need to isolate lengthy sections of the water main, drastically reducing water wastage compared to traditional replacement procedures.



Future Maintenance

With a permanent roll valve integrated into the fitting, the temporary isolation valve can be quickly connected for any future maintenance needs, providing immediate and reliable isolation.

INTRODUCTION NOVUS STOP

Product Specification

Sizes:

DN100 - DN2400

High-Pressure Performance:

Engineered to meet a **PN16** pressure rating for demanding environments.

Streamlined Isolation Head:

The simplified design eliminates the risk of jamming during the extraction process, ensuring smooth operational recovery.

Advanced Patented Sealing:

Our proprietary rubber head adapts to diverse internal pipe diameters, capable of accommodating a 200mm variance with a single tool.

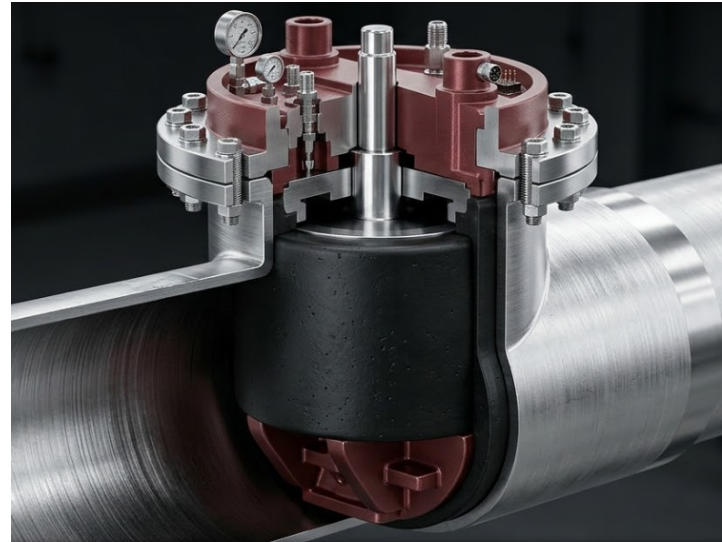

Product Component

Sealing Element:

High-grade NBR Rubber engineered for superior sealing integrity and seamless adaptability to various internal pipe geometries and surface conditions.

Isolation Head Construction: Manufactured from robust MS (Mild Steel) components, ensuring long-term durability and structural stability during high-pressure isolation.

Actuation Mechanism: Precision vertical movement controlled via a high-tensile SS316 Stainless Steel Stem, providing exceptional corrosion resistance and operational reliability.

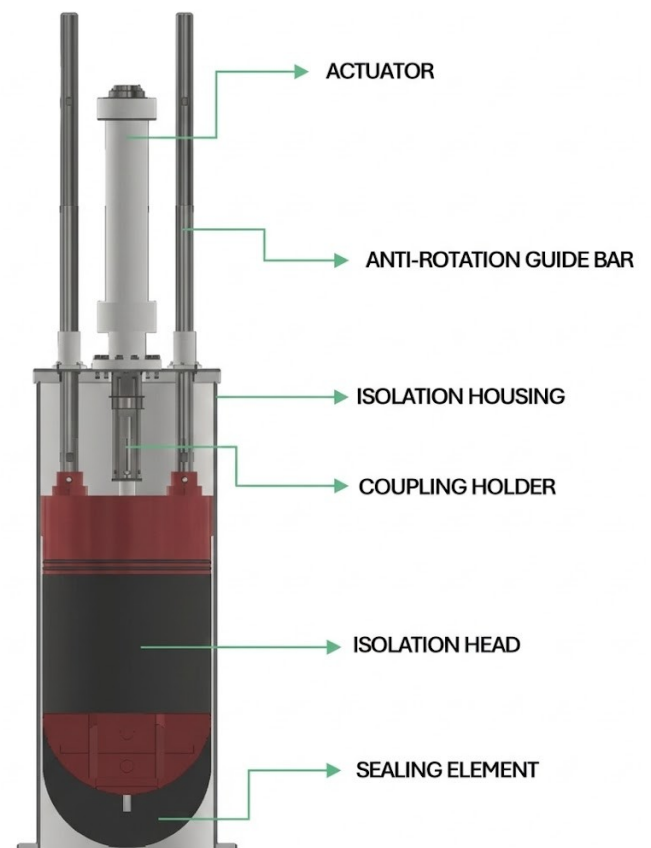

INDIVIDUAL COMPONENTS OF NOVUS STOP



FRONT VIEW OF ISOLATION HEAD

SIDE VIEW OF ISOLATION HEAD

BYPASS SIDE OF ISOLATION HEAD

SEALING ELEMENT

ASSEMBLED ISOLATION HEAD

✓ Streamlined Architecture:

A simplified, non-folding design with no internal drying mechanisms or longitudinal movement, ensuring a fail-safe, jam-free extraction.

✓ High-Pressure Integrity:

The robust Mild Steel (MS) body withstands extreme hydraulic loads, maintaining a rigid, leak-proof seal and eliminating the risk of "product popping" or deformation.

✓ Adaptive Radial Sealing:

High-level compression of the NBR element allows for dynamic expansion, accommodating various pipe conditions and large inner-diameter tolerances without equipment changes.

How Novus Stop Works



Isolation Head Insertion



Contact With Internal Pipe Surface



Compression & Rubber Expansion

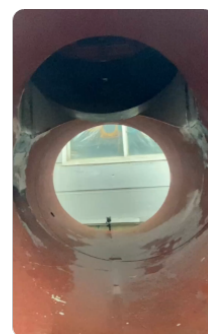

Extraction of the Novus Stop

FULL INSTALLATION PROCEDURE

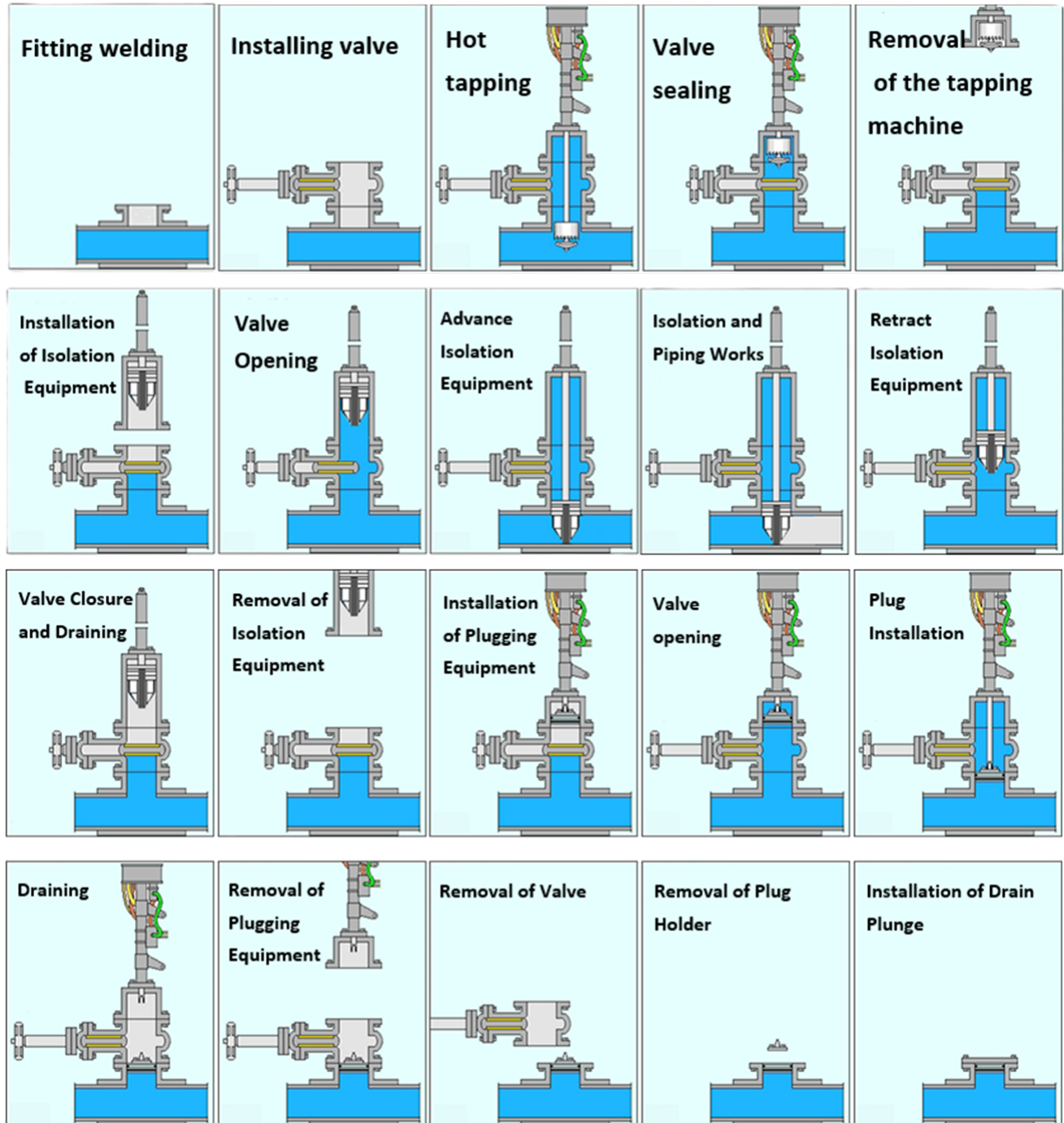

IMPLEMENTATION OF NOVUS STOP

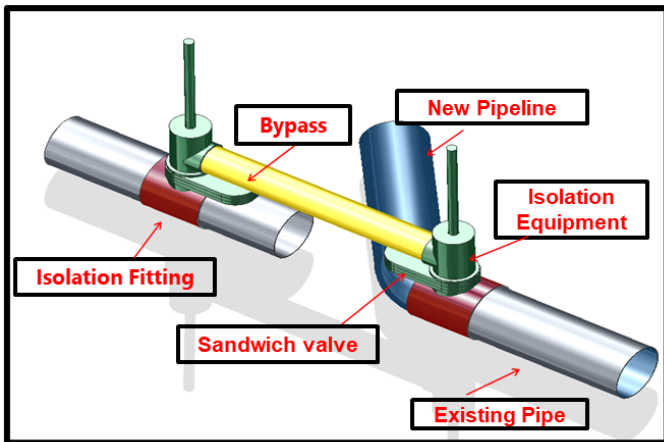

Direct Bypass

When configured in a dual-unit installation, the Novus Stop supports an integrated bypass system typically fabricated from Mild Steel (MS) to project-specific lengths. This bypass is mounted directly onto the linestop architecture, ensuring uninterrupted water service and maintaining full hydraulic bypass capacity during critical pipe relocation works.

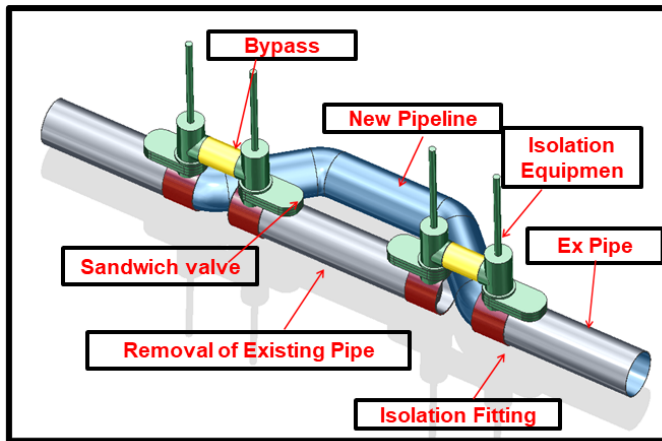

New Pipeline

"In scenarios where the span between primary isolation points is excessive, multiple Novus Stops can be deployed to repurpose the existing main as a temporary bypass, ensuring operational continuity while the new pipeline is under construction

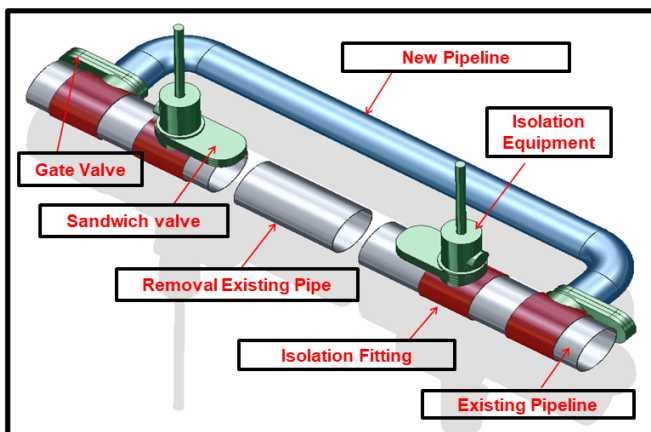

Hot Tapping new Line

"For applications where a bypass is not required, the Novus Stop provides a high-integrity singular isolation point. In these configurations, a concrete thrust restraint is mandatory to counteract thrust forces and prevent pipe movement once the section is removed.

PRODUCT DEMPLOYMENT

Inspection Process 1

Verify the integrity of both the existing rubber seal and the isolation plug, ensuring they are entirely free from damage prior to installation. to the plug.

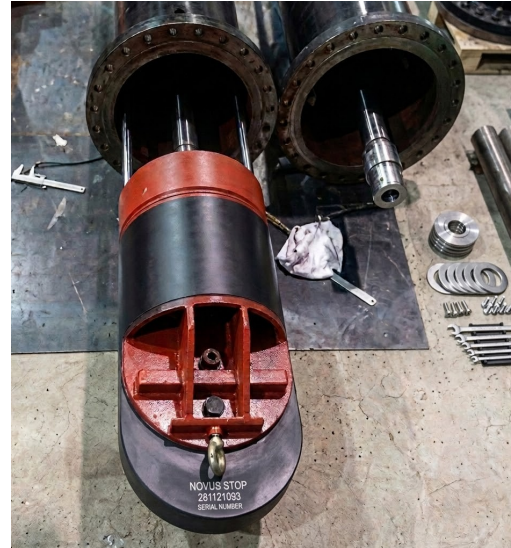

Inspection Process 2

Verify the integrity of both the existing rubber seal and the isolation plug, ensuring they are entirely free from damage prior to installation. to the plug.

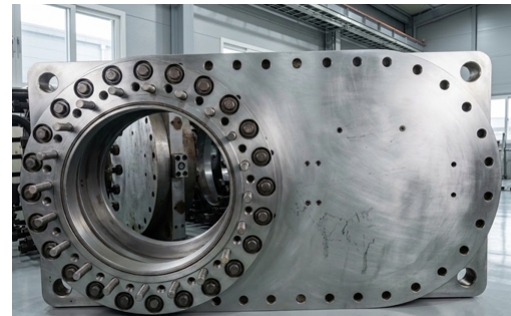

On Site Process 3

Either a compression fitting or an MS flange is welded onto the existing trunk main. A hydrostatic pressure test must be performed prior to drilling to verify that the installation conforms to all operational requirements.



PRODUCT DEPLOYMENT

On Site Process 4

Mount the drilling equipment onto the assembly and execute the penetration in accordance with the established procedure. Once the drill is complete, the temporary valve must be set to the CLOSED position before the drilling equipment is decommissioned and removed.



On Site Process 5

Mount the Novus Stop machine to the assembly, then deploy the line stop plug in accordance with the manufacturer's manual. Once deployed, verify a complete isolation of the main before proceeding with downstream works.



NOVUS STOP IN ACTION



www.aquanovus.net

AQUANOVUS
Innovative Aqua Engineering

Jason Taylor

E-mail. Jason@aquanovus.net **Tel.** +44 7931 603 606

SCAN TO CONTACT
GLOBAL REACH
EMEA SALES DIRECTOR

